

Mr. Gerald Holland
Clay County Appraisal District
PO Box 108
Henrietta, TX 76365

Re: Home at address 212 N Rodgers Parcel #12788. Suit 2008-0000159.

The above described property was struck off to the Clay County Trustees in April of 2015 at a Clay County Tax Sale. I would like to offer a bid in the amount of \$5,000 to purchase this property. There are many exterior problems with the property. Not able to view the interior to see what problems are there. Please feel free to contact me with any questions.

Sincerely yours,

Handwritten signatures of Rocky Murphy and Lisa Murphy in black ink. Rocky's signature is on the left and Lisa's is on the right.

Rocky Murphy and Lisa Murphy
608 Brown Road
Henrietta, TX 76365
Phone : 631-4472

OWNER/SEQ: 85727/1
 OWNER INT: 1.000000
 HS CODE:
 DISABLED VET:
 CEILING YEAR:
 CEILING TAX:

LEGAL 1: LT 5 SHEER EST
 LEGAL 2:
 LEGAL 3:
 LEGAL 4: 212 N RODGERS
 PROP ADDR: 212 N RODGERS
 HENRIETTA TX 76365

MTG:
 AGENT:
 LAST APPR YEAR: 2015
 LAST APPR DATE: 04/07/2015
 LAST APPR NAME: GMH
 MAP: HEN-1/2
 GPS:

CLAY COUNTY TRUSTEE
 PO BOX 108
 HENRIETTA TX 76365

ROUTE CODE/ORDER: 0/0

SEQ	ACRES	SQ.FT.	FRONT	REAR	FFAVG	DEPTH	DEP.%	CLASS	COST	%GD	%RD	EXTRA	MKT VAL	PROD CLASS/CD	PROD COST	TYPE	%GD	PROD EXTRA	PROD VAL
1	0.176	7,670	65	65	65	118.00	1.00	FF-R18	50.00	1.00	1.00	0	3,250	/	0.00		1.00	0	0
BLDG TYPE	CLASS	HS	YR BLT	EFF YR	AGE	COND	NOTES	TOT AREA	COST	EX COST	%GD	%FC	%EC	%CP	%EX1	%EX2	EXTRA VAL	TOTAL VALUE	
1	RV3	Y	1972	0	43		RESIDENTIAL BRICK VENEE	1,155	54.49	1.50	0.20	1.00	1.04	1.00	1.00	1.00	0	13,450	
2	AG2	Y	0	0	0			288	16.35	0.00	0.20	1.00	1.04	1.00	1.00	1.00	0	980	
3	PAT	Y	0	0	0			216	10.90	0.00	0.20	1.00	1.04	1.00	1.00	1.00	0	490	
4	PR2	Y	0	0	0			180	13.62	0.00	0.20	1.00	1.04	1.00	1.00	1.00	0	510	
5	ST2	Y	0	0	0			220	4.50	0.00	0.65	1.00	1.04	1.00	1.00	1.00	0	670	
IMPROVEMENTS										TOTAL MKT: 19,350									

ACRES: 0.176 OWNERS ACRES: 0.176 LARGER TRACT: 0.000000
 ABST NUM: SIC CODE:
 ABST/SUBDIV: IRR WELLS:
 TRACT/LOT: IRR ACRES:
 BLOCK: CAPACITY:

NOTES
 STRUCK OFF TO CLAY COUNTY TRUSTEE 4-7-15 GMH. NEEDS ROOF BAD. HOUSE IS IN POOR CONDITION.

SEQ	COMMENTARY	VALUE	UNIT
1	BRICK VENE	0.00	U
1	CENT H/A	1.50	
1	FAIR COND	0.00	
1	GABLE/COMP	0.00	

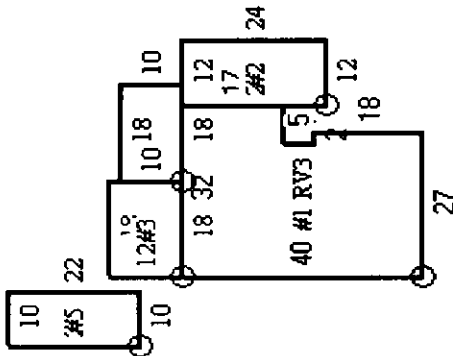

PREVIOUS OWNER

SEQ	PREVIOUS OWNER	DEED DATE	VOLUME	PAGE	FILE NUM
6	JOHNSON CODY	04/21/2015	70	854	11500
5	JOHNSON FRANCES G	04/18/2007	0	0	WILL
4	MOORE ROWDY J	04/05/1995	433	3	